



SKYMAX FLEETWOOD RETRACTABLE ROOF SYSTEM

Extend your living area with The SkyMax Fleetwood System. An intelligent all-in one solution that protects you from the elements, while delivering functionality with style. Utilising the latest technology, the system is manufactured to the highest quality. With a rich timber element for innovation & style, the Fleetwood surpasses all other shade systems in the market.

Protection – Delivering optimum protection against sun and rain, The SkyMax Fleetwood System has been designed and engineered to withstand wind speeds of up to 90km/hr. With a maximum width of 15 metres, and projection of 6 metres, the system allows protection up to 100 square metres.

Functionality – The SkyMax Fleetwood System will not confine your area or add additional heat during the warmer months of the year, unlike conventional roofing or louvered systems. The SkyMax Fleetwood is easily extended or retracted with the remote control, allowing you to stop the awning at your desired position.

Technology – We pride ourselves on utilising the latest technology from Europe & Australia, enabling us to bring the most modern & stylish systems available to the market.

Quality – The SkyMax Fleetwood System is European in design & manufactured in Australia by our highly skilled team. Quality is always one of our highest priorities, ensuring total customer satisfaction in everything we do.

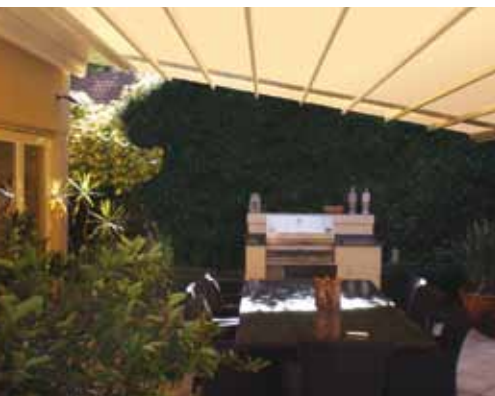

SKYMAX FLEETWOOD RETRACTABLE ROOF SPECIFICATIONS

Please note illustrations are not to scale. All measurements are in millimetres. Please contact your Tecnic representative for additional information.

Typical fixing detail

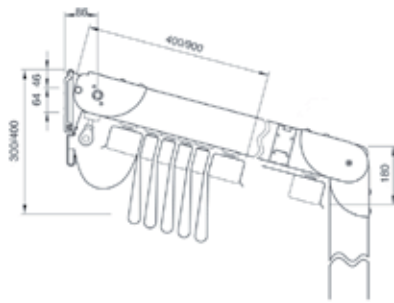

Maximum width 5,000mm centre/centre of runner

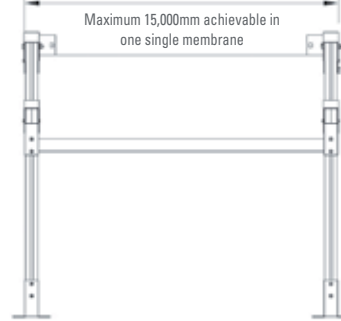

Contemporary Fleetwood support structure

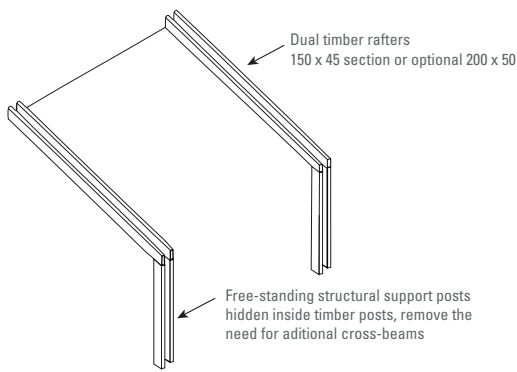

Traditional Fleetwood support structure

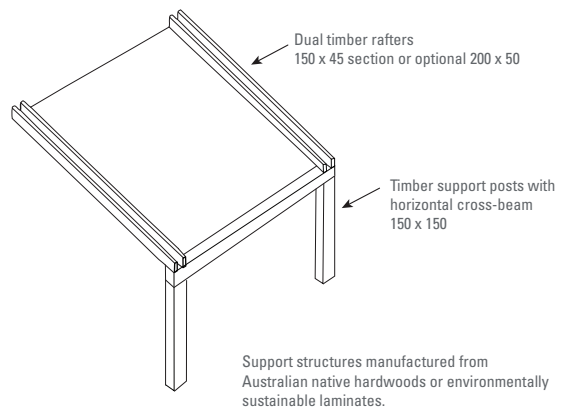

SIZES	
WIDTH & PROJECTION	Max. width 15m - Max projection 6m
OPERATION	
TYPE	Motorised / Manual
HARDWARE	
MATERIAL	All components made from non-corrosive materials, including 316 stainless steel connectors & bolts. 6061 grade extruded aluminium support frame (available in over 200 colours)
FABRIC OPTIONS	
	Reinforced high-tensile polyester core PVC (Preconstraint Ferrari 502) Ferrari Soltis 86/92 reinforced high-tensile polyester core sunscreens
CONTROL OPTIONS	
	Integrated lighting modules
	Integrated electric radiant heat panels
	Integrated self zipping motorised blinds & curtains
	Integrated drainage system
REGISTERED DEALER	
	Designer Shade Solutions - PO Box 929, Mittagong, NSW 2575
	P: 02 8006 2276
	Email: info@designershadesolutions.com.au