

ROLTEX MARCHINI CASSETTE FOLDING ARM AWNING SYSTEM

Compact, reliable and perfectly finished. The Roltex Marchini Cassette Folding Arm Awning System has been intelligently designed and engineered utilising the latest German manufacturing techniques.

Protection – The Roltex Marchini Cassette Folding Arm Awning offers complete protection against harsh ultra violet rays. The ergonomic design allows for up to 14000mm coverage in width and 3500mm in projection. Our marine grade textiles offer the best compromise between visibility and light transmission, while providing incomparable weather resistance and ease of maintenance.

Functionality – Designed utilising innovative concealed mounting brackets, this ensures the ergonomically designed cassette appears clean and minimal in appearance. Lateral stability is achieved thanks to the Kombi Arm Assembly, ensuring fabric tension is maintained in all positions.

Technology – All components are manufactured from heavy-duty drop forged aluminium, our unique cassette utilises 6061 grade extruded aluminium, components are protected with a durable powder coat finish (Dulux Powder Coat Chart).

Quality – Designed, engineered and manufactured in Germany, Certified ISO 9001 and safety tested by German TUV Product Service. Roltex Marchini Cassette Folding Arm Awnings Systems are assembled under German quality guidelines and assembly processes in Australia. Tecnic offers our experienced network superior quality and service that you can rely on.



ROLTEX MARCHINI CASSETTE FOLDING ARM AWNING SPECIFICATIONS

Please note illustrations are not to scale. All measurements are in millimetres. Please contact your Tecnic representative for additional information.

FIXING METHODS

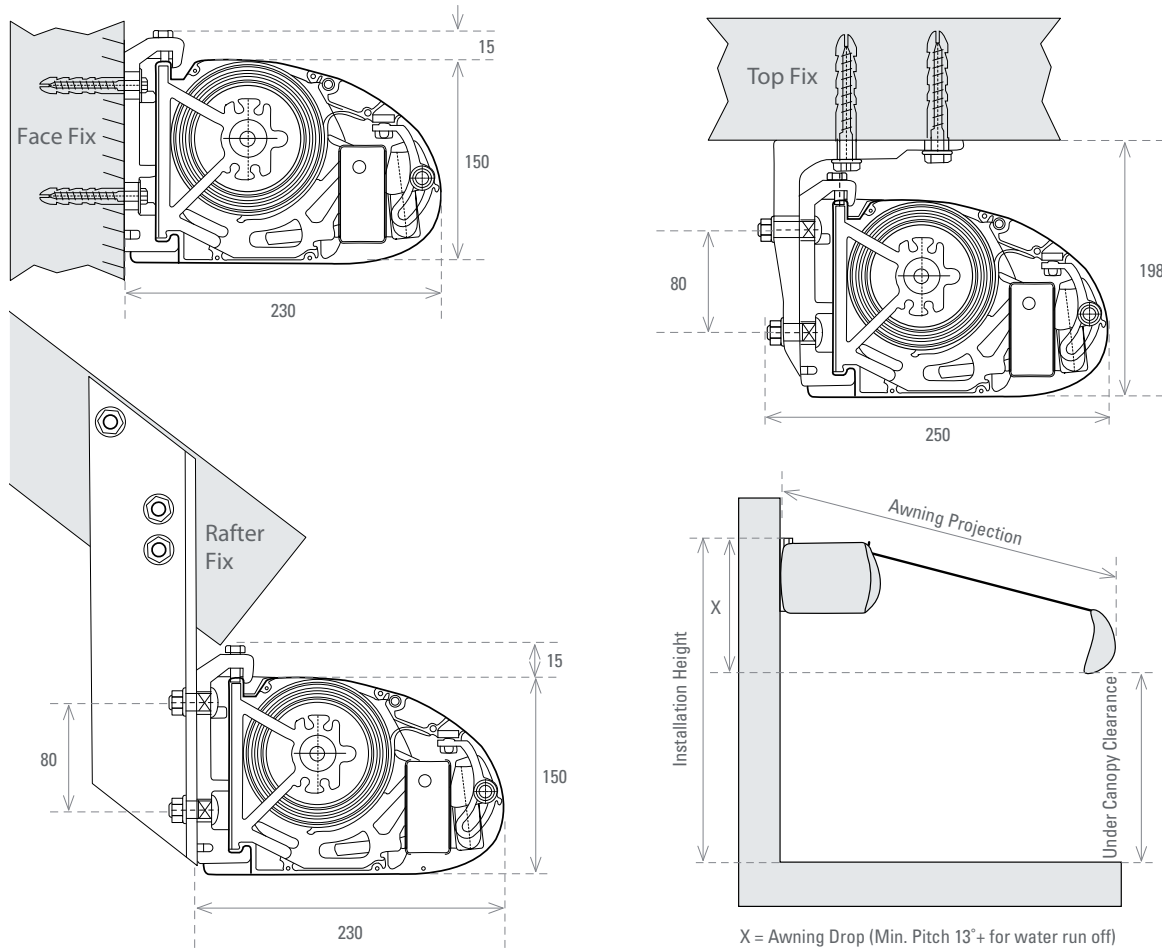

AVAILABLE SIZES

WIDTH	Max. 14000mm (over 7000mm coupled fabric applies) / Min. 2000mm
PROJECTION	Max. 3500mm / Min. 1500mm

HEADBOX

MATERIAL	6061 grade extruded aluminium
DIMENSION	Height: 165mm top/bottom, Depth: 230mm front/back
FINISH	Standard finish is clear anodised or for custom colour select from Dulux Powder Coat Range

TOP ROLLER

MATERIAL	80mm diameter heavy-duty extruded aluminium
----------	---

ARM ASSEMBLY

MATERIAL	6061 grade extruded aluminium with 4mm wall thickness
INTERNAL SPRING ASSEMBLY	Heavy-duty 8 gauge tensile steel dual spring assembly with dual 3mm PVC coated 316 stainless steel cable providing unparalleled fabric tension

END CAPS

MATERIAL	Powder coated cast aluminium providing a minimal profile appearance ideal for reveal installations
----------	--

FIXING METHODS

TYPE	Concealed mounting brackets for face fixing, top fix and rafter brackets are also available
------	---

CONTROL OPTIONS

CRANK OPERATION	Cast aluminium, 5.1 ratio, Gear 130X with extruded aluminium crank mechanism
ELECTRIC MOTOR	Tubular motor mounted internally within top roller. Aluminium case complete with built-in limit switches. Extensive range of control options available

FABRIC OPTIONS

MARINE GRADE ACRYLIC	100% dope dyed acrylic "Sunacrylic" fibre - Dickson Orchestra available
SUNSCREEN MESH	High tenacity polyester core yarn sunscreen - Soltis 93 (5% openness) Soltis 86 (%15 openness)

REGISTERED DEALER

Designer Shade Solutions - PO Box 929, Mittagong, NSW 2575
P: 02 8006 2276
Email: info@designershadesolutions.com.au